

Polarization-Maintaining Fiber V-Groove

(SM, PM, 1xN, 10W, 20W, 30W)



DATASHEET

BUY NOW



Features

- Low Loss
- High Reliability

Applications

- 40G Communication

The PM V-Groove arrays are mass produced to be incorporated in various photonic devices, particularly for high speed 40 Gb/s to next generation 100 Gb/s coherent detection systems. The arrays are manufactured using Pyrex V-Groove substrates in conjunction with a Pyrex lid or precision silicon wafer V-Groove, enabling sub-micron alignment accuracy with UV cure attachment capabilities. We offer V-Groove array assemblies available with polarization maintaining (PM) fibers or different types of fibers assembled into a single array. Standard PM arrays are manufactured with the polarization axis (stress rods) aligned vertical to the V-Groove base within 3°. High grade assemblies with one to eight channels can be provided with the stress rods aligned to 1°. Arrays can also be provided with the fibers aligned parallel to the base, alternating axes or at custom angles. When supplied with a breakout and connectors, the alignment of the connector is also to the slow axis, within 3° for standard connectors or available to within 1.5° for high grade connectors.

V-Groove array assemblies can be manufactured with a hermetic feedthrough attached. This enables the development of multichannel photonic devices capable of meeting Telcordia requirements. Fiber breakouts can also be added, to convert ribbonized fibers into separated fibers, capable of being connectorized.

Multichannel Array Specifications

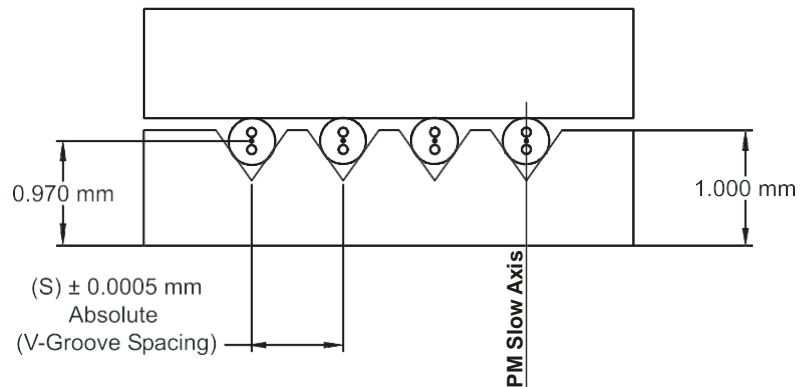

Rev 08/23/24

© Photonwares Corporation

P +1 781-935-1200

E sales@photonwares.com

W www.agiltron.com

Polarization-Maintaining Fiber V-Groove

(SM, PM, 1xN, 10W, 20W, 30W)



DATASHEET

Dual Channel Specifications

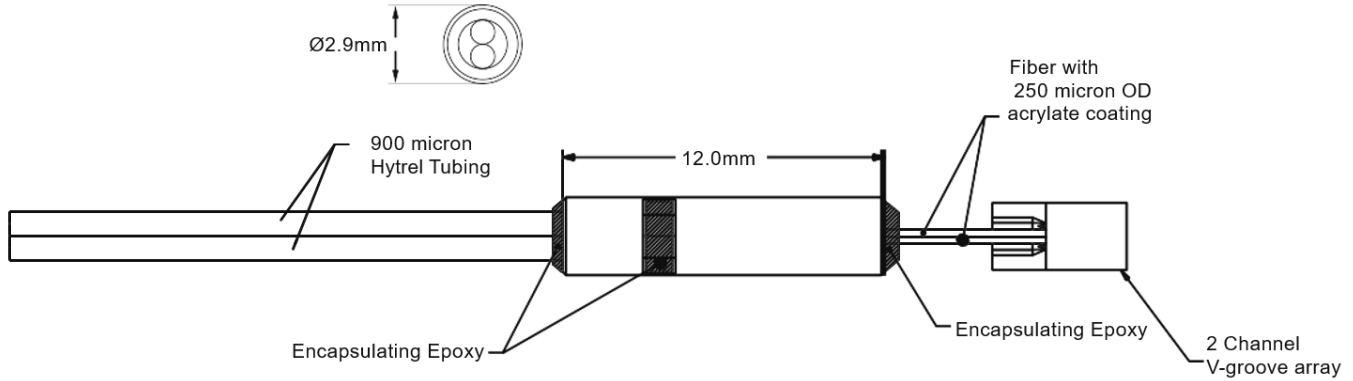

Polishing Face Angle Selection

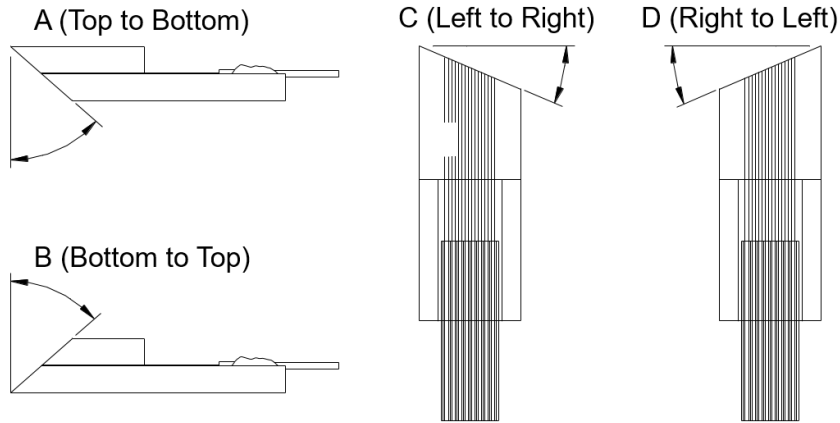

*Product dimensions may change without notice. This is sometimes required for non-standard specifications.

Ordering Information

Prefix	Number of V-Grooves	V-Groove Spacing	Angle Polish	Face Direction Angle	V-Groove Dimension	Fiber Type	Fiber Cover	Fiber Length	Connector
PMVG-	2 = 2 8 = 8 16 = A 32 = B N = N	250 μ = 1 127 μ = 2 400 μ = 4 500 μ = 5 Special = 0	0° = 1 8° = 2 Special = 0	Flat = 1 A = A B = B C = C D = D	Standard = 1 Special = 0	PM1550 = B PM1310 = 2 SM28 = 1 55/125 = 4 60/125 = 5 105/125 = 6 Special = 0	250 μ = 1 2mm = 2 3mm = 3 900 μ = 4 200 μ = 5 300 μ = 6 400 μ = 7 Special = 0	0.5m = 1 1m = 2 2m = 3	None = 1 FC/PC = 2 FC/APC = 3 LC/PC = 4 LC/APC = 5 SC = 6 MU = U Special = 0

Special – customer spec not listed on the datasheet